

FlowSwitch FS 750

**Dust monitoring and filter break detection
with analog output**



Application

The FlowSwitch FS 750 monitors the dust concentration behind a bag or cartridge filter. It is installed on the clean air side of the filter. It identifies if a filter is damaged, e.g. by cracks, fractures or assembly errors, and gives a trend analysis of the dust concentration. This allows to replace a damaged or broken filter in time, without losing production time and without polluting the shopfloor or environment.

Dust monitors are especially important in case of heavily contaminated air, recirculation into the factory, strict external emission limits or dust reusage.

Scope of use

Aluminum
Bakeries
Building materials
Cement industry
Chemical industry
Fertilizer industry
Food industry
Glass production
Mills
Pharmaceuticals
Power plants
Pulp and Paper

Steel industry
Surface cleaning
Wood industry
etc.

Main Benefits

- Prevents uncontrolled dust emissions and unnecessary cleaning due to damaged dust filters
- Ensures recircled air is always clean
- Ensures that strict emission limits are fulfilled
- Saves the company from investing into additional police / emergency filters
- Very reactive and fast detection of filter damage
- Is not affected by dust buildup on the rod
- Robust design, well protected for several years of operation in a harsh environment
- Wear- and maintenance free
- Simple automatic calibration
- Easy to install into existing air ducts

Function

The measurement of the FS 750 is based on the triboelectric effect. Particles collide permanently with each other and are charged in a natural way. If these electrically charged particles are flying next to the sensor rod of the FS 750 or touch it, the particles are detected via a charge transfer. Resting particles, such as deposits etc., do not affect the measurement. An installation into an existing exhaust duct is possible without any problems.

The sensor has an analog output (4-20 mA) which indicates the dust level. It can be used as trend signal to ensure that the filter is exchanged when showing first signs of wear and replaced immediately when it is broken. The signal is available from a transmitter which is installed on a DIN rail in the switching cabinet and which will transmit the analog signal to a PLC.

The design of the sensor is optimized for a long lifetime, and the unit is completely free of maintenance. A dedicated ATEX version is available and can be used up to zone 20/21.

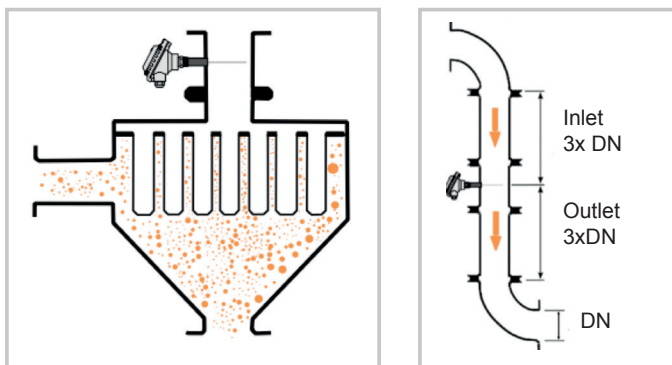

A FS 750 on the clean air side of a filter and in a pipe

To install a FS 750 a threaded socket is welded onto the pipe and a small hole for the sensor rod drilled. The sensor is fixed on the socket. The rod length should be at least 1/3 of the pipe diameter and the rod must not touch the opposite side. Calibration is done in clean air over a measurement period of 10 min. Sensitivity can be adjusted manually. Retrofits into existing ducts are easy and can be done within minutes.

Technical Data

Housing material	Aluminum
Sensor rod	Stainless Steel (1.4571)
Rod length	250 mm, 500 mm or customized
Mech. connection	NPT 0,5"
Ambient temperature	-20°C to +50°C -10°C to +70°C (ATEX vers.)
Process temperature	-20°C to +150°C -10°C to +180°C (ATEX vers.)
Process pressure	0 – 2 bar 0,8 – 1,1 bar (ATEX vers.)
Protection class	IP65
Ex protection / ATEX	Optional up to Zone 20/21
Power supply	24 VDC
Current consumption	Max. 50 mA, <2W
Output	4-20 mA
Output load	max. 750 Ω
Adjust. parameter	Sensitivity
Calibration	Automatically over 10 min
Indicators	Multi color LED for the dust level (Non-ATEX vers. only)

